

FB

Suzuki

(19)日本国特許庁 (J P)

(12) 特 許 公 報 (B 2)

(11)特許出願公告番号

特公平6-105415

(24) (44)公告日 平成6年(1994)12月21日

(51)Int.Cl. <sup>5</sup>	識別記号	庁内整理番号	F I	技術表示箇所
G 0 5 D 1/08	Z	9323-3H		
B 2 5 J 5/00	E	8611-3F		
	Z			
B 6 2 D 61/04				
G 0 5 D 1/02	H	9323-3H		

請求項の数6(全6頁) 最終頁に続く

(21)出願番号	特願昭63-149523	(71)出願人	999999999 特芸株式会社 東京都北区上中里2丁目21番10号
(22)出願日	昭和63年(1988)6月17日	(72)発明者	鈴木 輝明 東京都北区上中里2丁目21番10号 特芸株式会社内
(65)公開番号	特開平1-316810	(74)代理人	弁理士 井沢 洵
(43)公開日	平成1年(1989)12月21日		審査官 首澤 洋二

(64) 【発明の名称】 自立型搬送機並びにそれによる自動搬送装置

1

【特許請求の範囲】

【請求項1】 縦長に形成された搬送機本体と、その下部に一軸上に配置された左右2箇所の走行手段と、該走行手段を各別に作動させる駆動機構と、走行時に前記軸方向と平行に収容され、停止時は前記軸方向と直交する方向に移動し走行手段の前後に位置して搬送機本体を支える停止時自立手段とを備え、走行手段の作動により自立走行を行なうことを特徴とする自立型搬送機。

【請求項2】 搬送機本体は、上部に、搬送物を収容する容器状アダプタ若しくは作業用のアクチュエータ等を着脱交換可能に備えている請求項第1項記載の自立型搬送機。

【請求項3】 走行手段として一軸上に配置された2個の車輪を備え、また停止時自立手段として2個の車輪間に収まる間隔に配置された2個の小輪を備えており、2個

2

の小輪は走行時に前記車輪と平行の格納位置をとり、停止時前記車輪と直交の位置をとるように構成された請求項第1項記載の自立型搬送機。

【請求項4】 搬送機本体は平衡センサと該センサにより検出された前後方向の傾きを減少させる方向に走行手段の回転方向と回転数を修正する演算装置を内蔵している請求項第1項又は第3項記載の自立型搬送機。

【請求項5】 一軸上に配置された2個の車輪の回転により自立して走行するように構成された自立型搬送機と、停止時に自立型搬送機を出入可能に直立状態で保持する複数のステーションとによって構成された自動搬送装置。

【請求項6】 ステーションは自立型搬送機に内蔵された平衡センサをリセットする矯正機構と、データの送受を行なう端子と、内蔵の電源電池を充電するための端子を

10

備えている請求項第4項記載の自動搬送装置。

【発明の詳細な説明】

(産業上の利用分野)

本発明は自立型の搬送機と、それによる自動搬送装置に関するものである。

(従来技術)

現在搬送用ロボットと呼ばれるものは3輪以上の台車型が殆んどを占めており、この型は重心が低く、安定感があり、重量物の積載にも耐える利点を持っている。しかし、

①台車の占める床面積が大きい、

②スピードが遅い、

③安全面に問題がある、等

の短所もあるため、特にOA、MA或いは将来のHA分野に於る搬送機としては不向きである。

占有面積の小さいものとしては2足歩行型のものがあり、例えば特開昭62-97005号が開示されている。

(技術的課題)

しかしながら2足歩行型の実用化には、例えば電圧等に応じて自由に伸縮する人工筋肉、神経のように繊細かつ小型で高感度のセンサそしてパワフルな動力源等が必要であり、それらが開発されていない現段階では要求される機敏な動きを行なう自立型搬送機は現実化できないと考えられた。

本発明は前記の実情に鑑み幾多の経緯を経てなされたもので、その目的は通常の室内でも安全に使用できる装置システムであって、

①占有面積が可能な限り小さく、

②スピードが早く、機敏に動くことができ、

③人に当たっても危険性のない、

自立型搬送機とそれによる自動搬送装置を提供することにある。

(技術的手段)

このような目的を達する自立型搬送機の移動手段について研究開発を行なった結果、最も効率の良いのは車輪又はそれと同等のものを用いることであり、その駆動制御方式を適当なものとするにより慣性と、作用反作用の法則を利用した正確、迅速な移動が可能となることを見出した。

即ち本発明の自立型搬送機は、縦長に形成された搬送機本体と、その下部に一軸上に配置された左右2箇所の走行手段と、該走行手段を各別に作動させる駆動機構と、走行時に前記軸方向と平行に収容され、停止時は前記軸方向と直交する方向に移動し走行手段の前後に位置して搬送機本体を支える停止時自立手段とを備え、走行手段の作動により自立走行を行なうことを特徴とするものである。

左右2箇所の走行手段が前述の車輪に該当する。該走行手段は一軸上に離隔配置して軸方向への安定性を保つ

で、それと直交する前後方向のバランスのみを平衡セン

サ等により検出し、車輪等の回転制御により保てば良い。従ってこれは1軸2輪別駆動の方式であるということができる。

搬送機本体を縦長としたのは占有面積が少なく済み、安全性も確保し易いからである。特に筒状、柱状の場合2軸回りの慣性モーメントにより方向転換も容易であり、また前後方向のバランスも取り易い。

停止時自立手段は、走行手段を制御せずに搬送機本体を自立させる支えであり、一時的なりガー (rigger) であって、走行中は走行手段と平行にして走行の邪魔にならず、停止時は直交方向に向きを変えて停止指令により4支点で倒れるのを防ぐものである。

そして、一軸上に配置された2箇の車輪の回転により自立して走行するように構成された自立型搬送機と、停止時に自立型搬送機を出入可能に直立状態で保持する複数のステーションとによって構成された自動搬送装置によって、自立型搬送機が最も効果的に活用される。

(作用)

前記の構成を有する搬送機本体は、垂直に立てて保持した状態から手を放すと、走行手段の軸回り(前後)方向へ倒れようとするが、そこで倒れる方向に走行手段を作動させると、走行速度が適当であれば傾きが一定のまま移動し、走行速度が早ければ傾きは少なくなり、更に早くすると本体は鉛直に立って走行を継続することができる。

搬送機本体が停止するときは二つの方法で自立させることができる。その第1は前述の停止時自立手段によるもので、走行手段と合せて4支点で安定に自立するので比較的長期の待機等に向いている。第2は動的停止ともいうべきもので、本体が傾むくとそれを平衡センサ等により検出し、駆動機構を作動させ傾きが逆になるように調整するが、動力を消費するので短時間の停止用である。搬送機本体は、或る地点から或る地点へ移動するように管理されるが、そのため複数のステーションが要所に配置される。該ステーションは自立型搬送機を直立状態で受け入れ、送り出すと同時にその間保持するので、ステーションにあるときは自立型搬送機は停止時自立手段も動的停止管理も不要である。

搬送物は、搬送機本体に固定式或いは交換式に装備された保持手段にあずけられ、ステーションからステーションへ搬送されることとなる。

(実施例)

図面を参照して説明すると、搬送機本体10は第1図乃至第3図に示されている。11は円筒状のボディ、12はその下端に設けられた走行手段で2箇の車輪12a、12bが一つの軸1上左右に離れて配置されている。13aは左車輪駆動モータ、13bは右車輪駆動モータで、これらは走行手段を各別に作動させる駆動手段である。

14は停止時自立手段で小輪付きの2箇のインナーリガー14a、14bを備え、インナーリガー14a、14bは前記車輪12

a、12bの内側に位置し、その軸は前記軸1に対し平行な位置（走行時）と、直交する位置（停止時）の間で垂直軸回りに回転可能であり、該垂直軸はインナーリガー駆動モータ14dの駆動軸14cを兼ねている。第4図参照。なお15は走行手段12の取付部カバーを示す。

16は搬送物の保持手段で、搬送機本体10の頂部に設けられており、図面は搬送物を収容する容器状アダプタが取付けられた状態を示している（第1図～第3図）。保持手段16として別に搬送物を挟持するアームやハンド等を有するアクチュエータが用意され交換使用される。

17は平衡センサ、18は映像センサを示す。平衡センサ17は搬送機本体10の微小な傾きを正確に早く検出するために設けられ、例えばジャイロと振子を組合せロータリエンコーダにより傾きを検出する方法がとられる。映像センサ18は対象の識別や距離計測等に用いられ、また平衡センサ17と組合せられる。

19は受令及び制御装置で、ステーション21から有線又は無線で走行中に受ける命令、更に誘導ラインからのデータ処理、人や物に近づいたときの処置、平衡センサからのデータ分析などの機能を果し、さらに処理入力に応じた走行用のモータ13a、13b、インナーリガー用のモータ14dへの出力制御を行なう。また必要によって組まれる音声合成装置等とも結合してそれらを制御するためCPUを内蔵する。

20は電源電池で、以上の各素子、装置類に電力を供給し、それ自体はステーション21に於て、充電される。この電池は軽量、低内部抵抗、高速充電性のものを使用する。

ステーション21は1基又は2基以上の自立型搬送機10を直立状態のまま出入可能に保持するもので、例えば廊下や壁等の側面、機の側面等に設けられ、保持用の凹部22を上下に1組以上有する。該ステーション21は搬送機本体10の移動拠点であり、またそれが任務を終了したとき、トラブル発生時に入るように設定され、目的地提供のほか二つの役割を持つ。

その第1は搬送機本体10の姿勢矯正である。

即ち、搬送機本体10の垂直状態は平衡センサ17により検出されるが、経時的に誤差が累積し垂直状態をとらなくなる前にステーション21に於て姿勢を矯正するもので、上下の保持凹部22に磁気吸引したときに垂直を出し、内部センサをリセットして矯正する。23は極性反転可能な電磁石、24はデータ送受用の端子を示す。

第2は電力供給であり、搬送機本体10の側面に設けられた端子と接続する充電端子25を有し、充電電流を流す。26は誘導手段として床に設けた誘導ラインで、誘導方式としてはラジオコントロール式、電磁誘導式、光学式、赤外線式、マグネットテープ式（例示のもの）など、現在使用されているものがそのまま採用できる。ただ移動速度が早く、検知範囲が狭いのでシステム制御による進行方向、速度制御を行なうこととする。

作動

第7図(a)乃至(h)は走行と停止のしくみを示す。

(a)は作用の項で述べた動的停止による垂直自立状態で、(b)～(g)が走行開始から終了直前までを示す。(b)では走行方向への前傾角をつけるため車輪を逆方向へ回転させており、その後、車輪を進行方向へ回転させて走行状態に入り(c)、定速走行状態となり

(d)、傾きの大きなきは増速し(e)、傾きの小なきは減速し(f)、停止命令を受けると一旦増速して傾きを減少傾向としてからその減少につれて停止直前まで減速し(g)、垂直状態に入ったら車輪の回転を止めインナーリガーをセットする(h)。

第8図は急制動のしくみを示す。

第7図(d)で急制動を受令すると(第8図(a))、車輪回転を急加速して搬送機本体を起し(b)、負方向に傾けて車輪を急停止し、本体上部の慣性で垂直状態に仕向け(c)、インナーリガーをセットする。(d)。方向転換は第9図に示されている。

同図(a)では直進走行しており、右車輪の回転数を相対的に減少させて右回転し(b)、再度繰返すと(c)反転直進となり、左車輪停止によりUターンを行ない

(d)、或いは短秒時の片側車輪停止によりLターン(e)、更に直進から減速し停止と同時に左右各車輪を各々逆方向へ回転させてその場反転(f)を行なうことができる。その場反転はインナーリガーを出したままでも可能である。

外力を受けたときの対応

軸1の方向に外力が加わったとき、或る程度までは自己復帰するが、限界を越えると片側車輪が浮くので(第10図(a))、これを平衡センサ17により検出し、接地車輪を倒れる方向に加速して回り込むように運動を行ない収束に向わせる(同図(b))。

自動搬送システム

自立型搬送機10による自動搬送システムを第11図に示す。誘導ラインは主線100とそれより分岐した枝線101…を有し、枝線は各種ステーション21の保持凹部22へ導びかれており、各ステーションにはキーボード110が付属し、データ送受用の端子24を通じて自立搬送機10との間でデータ送受を行なう。全てのステーション21は全体制御CPU120によって外部制御されるように構成されている。130は動力充電用電源を示す。ステーション21はここでは前述の内容の他に搬送機10の行先データを与え、また搬送機10に入力されているデータを全体制御CPUへ送る作業を行なう。

今、或るステーションに保持されている搬送機10はその固定磁極と、ステーション側電磁石23によって磁気吸引された状態にあり、充電を受け、かつ鉛直リセットが行なわれた状態にある。そこへ「特定ステーションへ向え」というキーボード110から命令を受けると電磁石23の極性が反転し、搬送機10は押出されて、第7図の通り

の作動により誘導ラインをたどって走行を開始し、目的地へ到着後搬送物を収容して次の命令により再び次の目的地へ向う。走行中に命令を受けたときは受令及び制御装置19の作動により割り込み作業を行なってから元の作動状態へ復帰する。

(効果)

本発明は以上の如く構成されているので、次のような効果を発揮する。

- ①縦長であるため占有面積が極めて少ない。
- ②走行速度が早く、機敏に動作する。
- ③人に当たっても軽量なため安全である。
- ④自立性のため動作中倒れることがなく、外力を受けた場合でも倒れにくい。
- ⑤縦長であり、機敏なため狭い場所でも自由に使うことができる。
- ⑥水平面走行のほか傾斜面にも対応し易い。

⑦搬送機本体にデータキャリアシステムを搭載しマルチコントロールシステムの構築が容易に行なえる。

⑧単なる搬送のほか、各種アクチュエータの使用により、作業、看護、案内、監視、防災、防犯その他応用は多岐に亘る。

【図面の簡単な説明】

図面は本発明に係る自立型搬送機並びにそれによる自動搬送装置の実施例を示すもので、第1図は自立型搬送機の斜視図、第2図は側面図、第3図は正面縦断説明図、第4図は走行手段とその周辺の斜視図、第5図はステーションの斜視図、第6図は要部拡大斜視図、第7図は走行と停止のしくみを示す説明図、第8図は急制動の説明図、第9図は方向転換の説明図、第10図(a)、(b)は外力への対応と復原を示す説明図、第11図は本発明による自動搬送システムの部分説明図である。

【第1図】

【第2図】

【第3図】

【第4図】

【第5図】

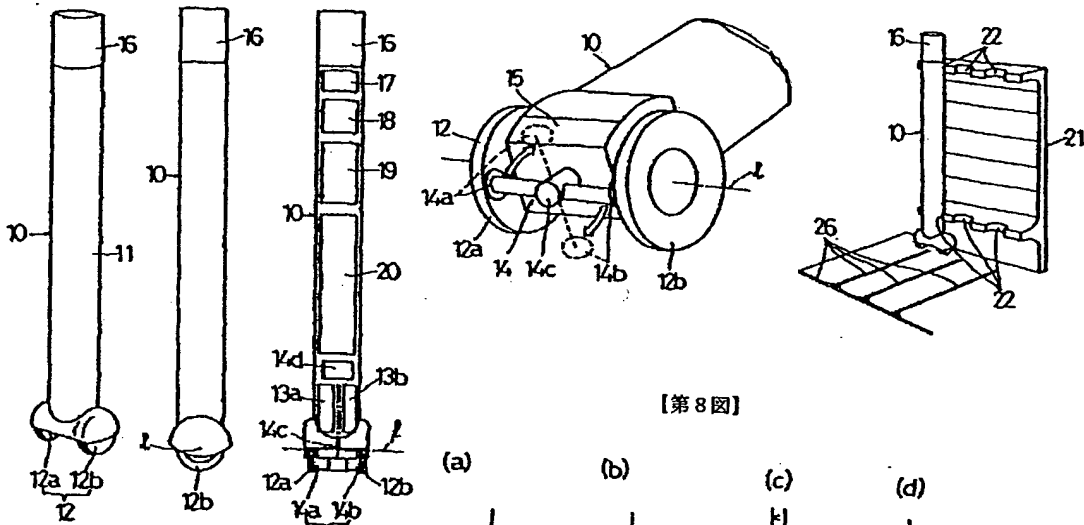

【第8図】

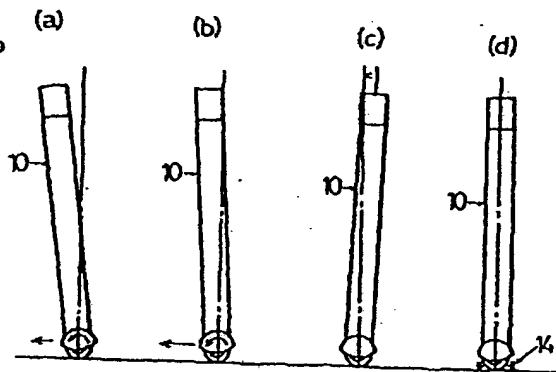

【第6図】

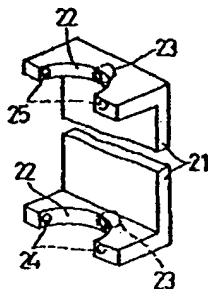

【第7图】

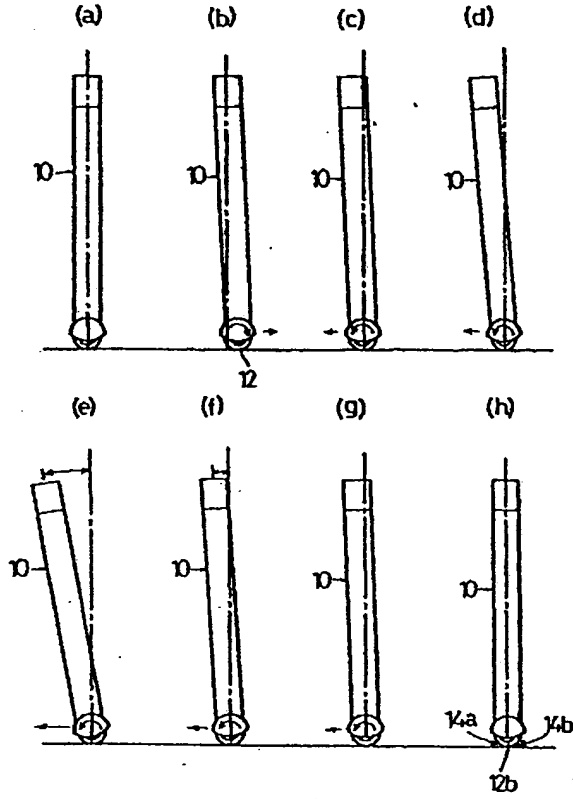

【第9图】

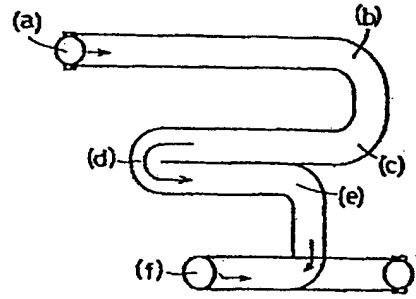

【第10图】

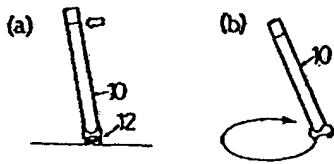

【第11図】

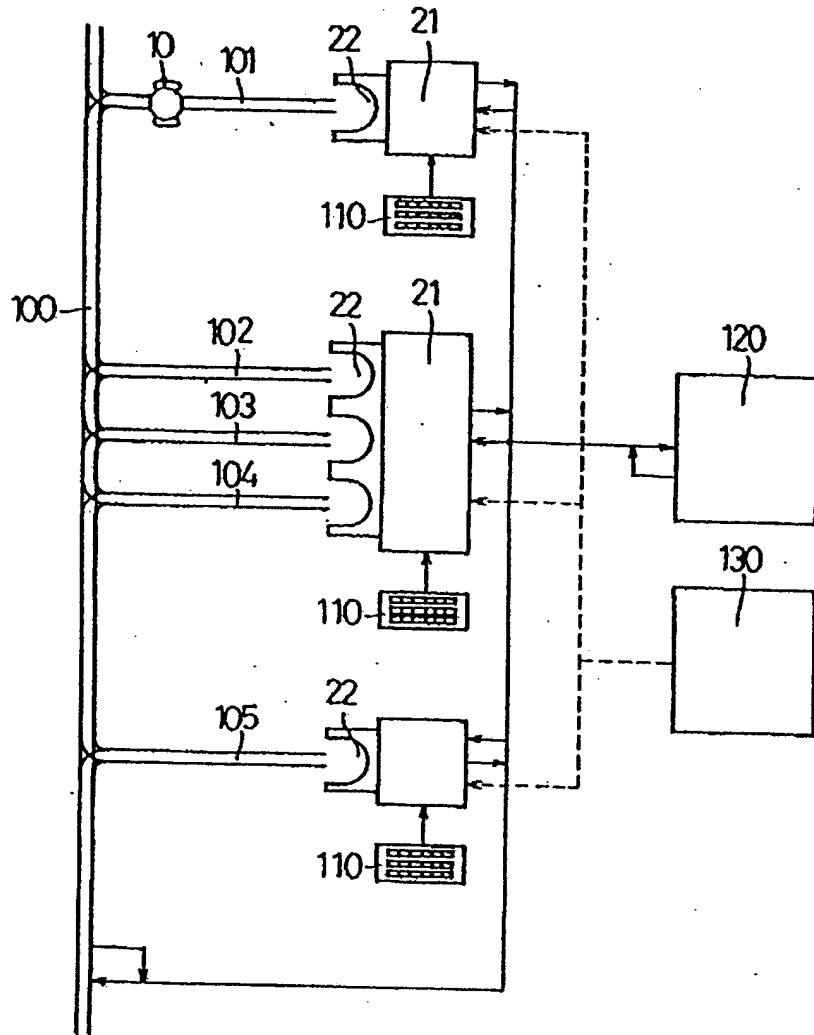

フロントページの続き

(51) Int. Cl.<sup>5</sup>

G 0 5 D 1/02

H 0 1 R 13/00

識別記号

庁内整理番号

F I

技術表示箇所

X 9323-3H

C 7319-5E

(19) Japan Patent Office (JP) (12) Official Patent Gazette (B2)  
(11) Patent Application Publication 6-105415  
(24) (44) Publication Date: December 21, 1994

---

(51) Int.Cl. <sup>5</sup>	Identifying Symbol	Intraoffice Adjustment Number	F1
G 05 D 1/08	Z 9323-3H		
B 25 J 5/00	E 8611-3F		
13/08	Z		
B 62 D 61/04			
G 05 D 1/02H	H 9323-3H		

**Technical Details**

Number of Claims: 6

(Total number of pages in the original: 6)

Continued on back page:

[Translator's note: this entry from the back page is being translated here]

Continued from front page

(51) Int. Cl. <sup>5</sup>	Identifying Symbol	Intraoffice Adjustment Number	F1	Technical Details
G 0 5 D 1/02		X 9323-3H		
H 0 1 R 13/00		C 7319-5E		

---

(21) Application Number 63-149523  
(22) Application Date: June 17, 1988  
(65) Publication Number: 1-316810  
(43) Publication Date: December 21, 1989

(71) Applicant: 999999999  
Tokugei Co., Ltd.  
2-21-10 Nakazato, Kita-ku  
Tokyo, Japan

(72) Inventor: Teruaki Suzuki  
Tokugei Co., Ltd.  
2-21-10 Nakazato, Kita-ku  
Tokyo, Japan

(74) Patent Representative: Patent Agent Makoto Izawa  
Examiner: Yohji Suguzawa

**[Title of Invention] Self-Sustaining Type of Carrier Machine and Automatic Carrier Device Based on It**

**[Claim 1]** A self-sustaining automatic carrier machine which is provided with (1) a carrier machine main body which has a vertical shape; (2) two traveling means located on the left and right which are disposed on a shaft on the lower part of the carrier machine main body; (3) a drive mechanism which operates the aforementioned travel means independently of one another; and (4) a self-sustaining means used for stopping which is housed parallel to the aforementioned shaft direction when it is traveling, which moves in a direction which is orthogonal to the aforementioned shaft direction when it is stopped, which is positioned at the front and the back of the travel means and which supports the main body of the carrier machine; and which can travel independently when the travel means are operated;

**[Claim 2]** The composition of Claim 1 wherein the carrier machine main body can attach, detach and replace a container-shaped adapter or an actuator used for operations which houses the object being carried on the top part;

**[Claim 3]** The composition of Claim 1 wherein it has the following configuration: it is provided with two wheels which are used as a travel means and which are disposed on the shaft; it is also provided with two small wheels which are disposed at an interval which is located between these [first] two wheels; the two small wheels are located at a containment position which is parallel to the aforementioned two wheels when traveling so that it is located at a position which is orthogonal to the aforementioned wheels when stopped;

**[Claim 4]** The composition of Claim 1 or Claim 3 wherein the carrier main body internally stores (1) a balancing sensor; and (2) an arithmetic unit which corrects the rotation direction of the travel means and the number of rotations of the travel means in a direction which reduces the inclination in the forward and back directions which are detected using the aforementioned sensor;

**[Claim 5]** An automatic carrier device which is configured of (1) a self-sustaining type of carrier machine which is configured so that it travels on its own due to the rotation of two wheels which are disposed on a shaft; and (2) multiple stations which retain the self-sustaining type of carrier machine at an upright position when it has stopped;

**[Claim 6]** The composition of Claim 4 wherein the stations are provided with (1) a straightening mechanism which resets the balance sensor which is internally stored in the self-sustaining type of carrier machine; (2) a terminal which is used to send and receive data; and (3) a terminal which is used to charge the internally stored power source batteries.

**[Detailed Description of Invention]  
[Technical Field]**

The present invention relates to a self-sustaining type of carrier machine and to an automatic carrier device based on it.



**[Description of the Prior Art]**

Virtually of the robots presently used for carrying are dolly-type models which have three or more wheels. This type of robot is advantageous in that it has a low center of gravity, it can be operated safely and it can withstand heavy loads. However, despite these advantages, they are not suitable as carrier machines particularly in the office automation, maintenance automation or the future home automation fields because of the following disadvantages:

- (1) the dollies take up too much space,
- (2) the units are slow,
- (3) they present safety problems, and the like.

A biped walking type of carrier machine which takes up little space has been disclosed in Laid-Open [Japanese] Patent 62-97005.

**(Technical Problems)**

Despite this, in order to put a biped walking type of carrier machine into actual practice, an intricate, small and highly sensitive sensor as well as a powerful power source are required such that it has artificial muscles and nerves which expand and contract at will in accordance with the voltage and other conditions. Currently this type of machine has not yet been developed and it was commonly thought that a self-sustaining type of carrier machine which can carry out these quick motions could not be realized.

The present invention takes the aforementioned situation into consideration and has gone through a great number of steps. It is an object of the present invention to provide a self-sustaining type of carrier machine and an automatic carrier device based on it which has a device system which can be used safely even in ordinary rooms and which:

- (1) take up as little space as possible,
- (2) are high speed and can operate quickly and effectively, and
- (3) which do not endanger the operator.

**(Technical Means)**

As a result of carrying out research and development on a means for moving a self-sustaining type of carrier machine which attained these objectives, it was found that the most efficient device used the same or similar wheels and that by using the appropriate drive control system, quick and accurate movements which used inertia and the third law of motion could be made possible.

Thus, the self-sustaining type of carrier machine in the present invention has the following characteristics. It is a self-sustaining automatic carrier machine which is provided with (1) a carrier machine main body which has a vertical shape; (2) two traveling means located on the left and right which are disposed on a shaft on the lower part of the carrier machine main body; (3) a drive mechanism which operates the aforementioned travel means independently of each another; and (4) a self-sustaining means used for stopping which is housed parallel to the aforementioned shaft direction when it is traveling, which moves in a direction which is orthogonal to the aforementioned shaft direction when it is stopped, which is positioned at the

front and the back of the travel means and which supports the main body of the carrier machine; and which can travel independently when the travel means is operated.

The two travel means on the left and the right correspond to the wheels mentioned previously. The travel means are disposed separately from one another on the shaft and maintain stability for the shaft direction. Only a balance at the front and rear directions which are orthogonal to these is detected by the sensor and may be maintained by controlling the number of rotations of the wheels. As a result, this can be called a "one-shaft, two wheel drive system".

The unit takes up very little space since the carrier machine main body has a vertical shape and its stability can be easily secured. In particular, when the device is cylindrical or columnar, the direction can be easily shifted by using (1) the inertia moment of the rotation of the Z shaft and (2) the balance between the front and rear directions.

The self-sustaining means for stopping is supported by making the carrier machine main body self-sustaining without controlling the travel means. It is a temporary rigger, it is parallel to the travel means while traveling and does not get in the way while the unit is traveling. While traveling, it changes the orientation of the orthogonal direction and is prevented from tipping over at the four points of support by a stop command.

Thus, a self-sustaining type of carrier machine can be used most effectively by using an automatic carrier device which is configured of (1) a self-sustaining type of carrier machine which is configured so that it travels independently of the rotation of the two wheels which are disposed on a shaft; and (2) multiple stations which maintain the self-sustaining type of carrier machine upright so that it can enter and exit.

#### **(Actions)**

When the carrier machine main body which is configured as indicated above is stood vertically and the operator releases his hand from the retaining position, it almost tips over in the direction of the turning (forward and backward) of the shaft of the travel means. However, when the travel means is operated in the tipping over direction at this point and if the travel speed is appropriate, the inclination moves while it is constant. If the travel speed is fast, the inclination declines. When the travel speed is further increased, the main body stands vertically and the traveling motion can be continued.

When the carrier machine main body is stopped, it can be made self-sustaining using two methods. The first method involves using the aforementioned self-sustaining means used for stopping. As a result, it is stable and self-sustaining at the four support points in tandem with the travel means and is suited for comparatively long standby situations. The second method might well be called "dynamic stopping". When the main body is inclined, this incline is detected using a balance sensor and is adjusted so that the drive mechanism is activated and the inclination is reversed. However, this method consumes motive power so that it can be used when the unit is stopped for short periods of time. The carrier machine main body is controlled so that it can be moved from one point to another and the multiple stations are disposed at key points for this purpose. These stations accept [an object to be carried] when the self-sustaining

type of carrier machine is maintained in an upright position. When [an object to be carried] is sent off, that space is maintained simultaneously so that when it is at a station, the self-sustaining type of carrier machine requires neither a self-sustaining stopping means or dynamic stopping monitoring.

The object being carried is held by a retaining means which is mounted on the carrier machine body in either a fixed or a replaceable fashion and it is carried from one station to another.

#### **(Practical Embodiment of the Invention)**

We shall describe the present invention referring to diagrams. The carrier machine main body 10 is indicated in Figure 1 through Figure 3. 11 is the cylindrical body, 12 is the travel means which is placed on the bottom end of this and two wheels 12a and 12b are disposed at a distance from one another on the left and right on the single shaft 1. 13a is a left wheel drive motor, while 13b is a right wheel drive motor. These motors are drive means which activate the travels means independently of one another.

14 is a self-sustaining means used for stopping and is equipped with two inner riggers 14a and 14b with small wheels attached. Inner riggers 14a and 14b are positioned inside the aforementioned wheels 12a and 12b. The shaft can rotate around a vertical shaft between a position which is parallel to the aforementioned shaft 1 (while traveling) and a position which is orthogonal to this (when stopped). The aforementioned vertical shaft also serves as a drive shaft 14c for inner rigger drive motor 14d. Please see Figure 4. 15 indicates the attachment part cover for the travel means 12.

16 is a means which is used to retain the object being carried. It is placed on the top of the carrier machine main body 10. The figures (Figure 1 through Figure 3) indicate the container shaped adapter which houses the object being carried when it is attached. An actuator--which is provided with an arm and a hand which clamp the object being carried independently of the retaining means--is provided and used for replacement purposes.

17 is a balance sensor and 18 is an image. The balance sensor 17 is placed so that it can quickly and accurately detect slight inclinations in carrier machine main body 10. It can be used for a method which is used to detect inclinations using a rotary encoder which has a combined gyro and a pendulum. The image sensor 18 is used to distinguish objects and to measure distance. It is combined with balance sensor 17.

19 is a command receiving control device. Its function is to (1) process commands received from station 21 by wire or by radio while traveling as well as data received from an inductive line; (2) carry out processing when the unit is approaching humans and objects; and (3) analyze data from the balance sensor. It carries out output control to motors 13a and 13b which are used for traveling according to the processing input and to motor 14d which is used for the inner riggers. An internally stored CPU which is used to control these may be combined with a built in voice synthesizer if necessary.

20 is a power source battery. It provides electrical power for each of the elements above and for the device itself. The battery itself is charged at station 21. The battery used should be light weight, it should be resistant inside the bottom part and should have high speed charging characteristics.

Station 21 retains the self-sustaining type of carrier machine 10 with one, two or more bases while it is upright so that it can enter and exit. It may be placed on the side of the wall and the corridor as well as on the side of a table. One or more sets of recessed part 22 used for retaining are provided on the top and on the bottom. The aforementioned station 21 is a strong point for moving the carrier machine main body. When it has fulfilled its duty, it is set so that it comes on the scene when trouble arises and carries out two other functions in addition to providing the target location.

One of these functions is to correct the position or posture of the carrier machine main body 10.

The vertical state of the carrier machine main body is detected by the balance sensor 17, however, it corrects the posture at station 21 before errors accumulate over time and it is no longer able to maintain a vertical state. As a result, verticality is provided when there is magnetic suction on upper and lower retaining recessed pieces 22 and the interior sensor is reset and corrected. 23 is an electromagnet with polar inversion capability; 24 is a terminal which is used to send and receive data.

The second function is to provide electrical power. It is provided with a terminal which is placed on the side of the carrier machine main body 10 and a charging terminal which is connected to this and sends a charging current. 26 is an inductive line which is placed on the floor as an inductive means. The inductive means may be the radio control type, the electromagnetic induction type, the optical type, the infrared type, the magnetic tape type (the one provided in the example) and any others which are currently being used. However, the moving speed is fast and the detection range is narrow so that the direction of the unit as it moves ahead and its moving speed can be controlled by using the system control.

### **Operations**

Figure 7 (a) through 7 (h) show the unit when it travels and stops. Figure 7 (a) indicates the unit when it is upright due to "dynamic stopping" which was described in the previous item (Actions). Figure 7 (b) through 7 (g) indicate the unit when the time that it starts to travel up to just before travel is completed. Figure 7 (b) indicates the wheels when they are turned in a reverse direction in order to provide a tilting angle for the direction in which the unit is traveling. Then, the wheels are turned in the direction in which the unit is traveling, the unit goes into travel mode (c), goes into constant speed travel mode (d), accelerates when the inclination is large (f) and decelerates when the inclination is small (f). When a stop command is received, the unit accelerates for a short time, then tends to reduce the inclination and decelerates as it declines until right before the unit stops (g). It stops wheels from turning once it is in a vertical position and sets the inner riggers (h).

Figure 8 shows how the unit is suddenly braked.

In Figure 7 (d), when a command for sudden brake is received, (Figure 8, (a)), the turning of the wheels is abruptly accelerated, the carrier machine main body is activated (b), the wheels are suddenly stopped in the negative direction, the unit is oriented to the vertical state by the inertia on the top of the carrier machine main body and the inner riggers are set. (d). The changing of direction is indicated in Figure 9.

In the same figure (a), the unit is proceeding straight ahead. The number of rotations for the right side wheel is reduced relatively and it turns to the right (b). When this is repeated (c), it goes into reverse and advances directly. It makes a U-turn by stopping the wheel on the left (d) or it makes a left turn by stopping the wheel on one side for just an instant (e). When the unit again slows down while advancing directly, both left and right wheels are turned in the opposite direction and a reverse motion can be made on the spot (f). This on-the-spot reverse can be carried out while the inner riggers are brought out.

#### **Handling External Force**

When an external force is applied in the direction of the shaft, the unit can return on its own to a certain extent. However, once a limit has been passed, the wheel on one side rises up so that (Figure 10 (a)) this is detected using the balance sensor 17. The unit is driven so that it accelerates and turns the wheels which make contact with the ground in a direction in which it may tip over and these are made to converge.

#### **Automatic Carrier System**

Figure 11 indicates the automatic carrier system based on the self-sustaining type of carrier machine 10. The inductive line is provided with a main line 100 and a branch line 101 which diverges from this. The branch line is introduced to retaining recessed part 22 on each of the stations. A keyboard 110 is provided for each of the stations. Data are sent from and received by the self-sustaining carrier machine 10 through terminal 24 which is used for sending and receiving data. All of the stations 21 are configured so that the external part can be controlled using the CPU120 which is used to control the entire unit. 130 is a motive force charging power source. At this point, the stations 21 provide lead data for the carrier machine in addition to the contents indicated previously. They also operate to send data which have been inputted to the carrier machine 10 to the CPU to control the overall unit.

The carrier machine 10 which is retained at a certain station is in a magnetic suction state due to the fixed pole on the carrier and due to the electromagnet 23 on the side of the station. The unit is charged and is in a mode where the vertical reset can be made. When a command is received from the keyboard 110 indicating "head to specific station", the polarity of the electromagnet is inverted and the carrier machine 10 is pushed out. The unit travels along an inductive line due to the operations indicated in Figure 7 and it reaches its destination. The object carried is housed and it heads to its next destination when the following command is received. When a command is received while traveling, the interrupt operations are carried out when the command is received and the control device 19 is operated. Then it returns to the original operating mode.

**(Effectiveness)**

The present invention is configured as indicated previously and is effective in the following ways.

- (1) The unit is vertical and takes up very little space.
- (2) Its traveling speed is fast and it operates quickly.
- (3) It is light-weight and safe even when it approaches humans.
- (4) It is self-sustaining and will not tip over during operations; it does not readily tip over even when an external force is applied.
- (5) It is vertical in shape and makes possible rapid movements so that it can be easily used even in tight spaces.
- (6) It can travel horizontally and can easily travel on inclined surfaces.
- (7) A data carrier system can be loaded in the carrier machine main body and a multi-system control system can be easily configured.
- (8) It provides simple carrying operations and has many applications including operations, supervision, guiding, observation, fire prevention and crime prevention since it uses a variety of actuators.

**[Brief Description of Figures]**

The figures indicate a practical embodiment of the self-sustaining type of carrier machine and the automatic carrier device which is based on it in the present invention. Figure 1 is an inclined view of the self-sustaining type of carrier machine. Figure 2 is a lateral view of same. Figure 3 is a frontal vertical explanatory view of same. Figure 4 is the travel means as well as a peripheral inclined view of same. Figure 5 is an inclined view of a station. Figure 6 is an expanded inclined view of the important parts of same. Figure 7 is an explanatory view of same indicating traveling and stopping operations. Figure 8 is an explanatory view of the quick braking operations. Figure 9 is an explanatory view indicating shifting of directions. Figure 10 (a) and (b) are explanatory views indicating how an external force is handled and how the unit rights [stabilizes] itself. Figure 11 is a partial explanatory view of the automatic carrier system based on the present invention.

**Captions**

<b>[Figure 1]</b>	<b>[Figure 2]</b>	<b>[Figure 3]</b>	<b>[Figure 4]</b>	<b>[Figure 5]</b>
[no text]	[no text]	[no text]	[no text]	[no text]

<b>[Figure 6]</b>	<b>[Figure 8]</b>
[no text]	[no text]

**[Figure 7]**

**[no text]**

**[Figure 9]**

**[no text]**

**[Figure 10]**

**[no text]**

**[Figure 11]**

**[no text]**

-----  
(Continued from front page)

(51) Int.Cl. <sup>5</sup>	Identifying Symbols	Intraoffice Adjustment Number	F1	Technical Details
G 0 5 D 1/02		X 9323-3H		
H 0 1 R 13/00		C 7319-5E		

[Translator's note: the above text has already been integrated in the text on the first page but is reproduced here for reference purposes and to maintain continuity with the original text].

01062/00C04 133364.1